

Lots of technologies use mirrors to change the way light travels from an object to your eye. See if you can trace the path of light in the technologies below!

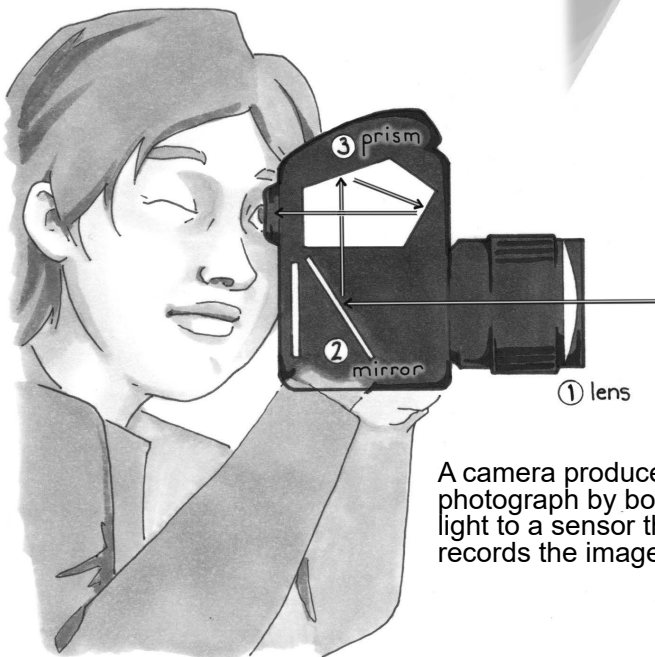

A telescope helps magnify and focus images from space.

The rear and side view mirrors in a car help you see what's in your blind spot while driving.

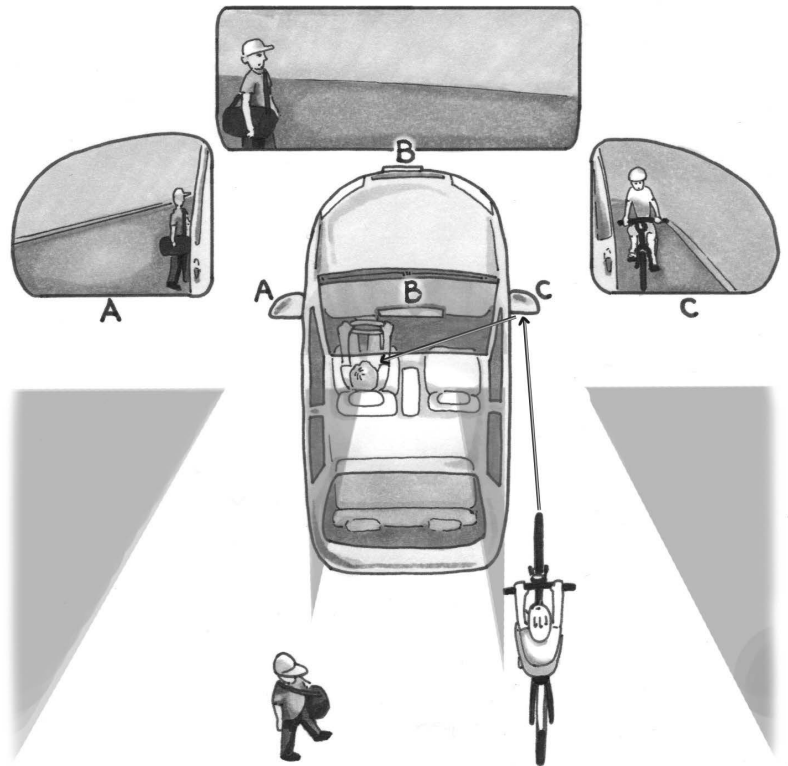

A camera produces a photograph by bouncing light to a sensor that records the image.

Did You Know?
There are lots of different kinds of telescopes, including the James Webb Space Telescope, which includes 18 hexagonal mirrors that unfold into a giant curved mirror after the telescope is launched into space.

Activity 1

Getting Started with Periscopes

1. Cut the manila folder in half to get two sheets. Put one half aside.

2. Fold one manila sheet in half longways, then fold it in half longways a second time. Unfold the manila sheet.

3. Fold the manila sheet into a box shape and tape it closed to make the periscope body.

4. Cut two mirror-sized rectangles out of the box on **opposite sides and opposite ends** of the box. Save these rectangles for the next step.

5. Use the two rectangles to create mirror stands. Fold and tape the rectangles into a triangle shape.

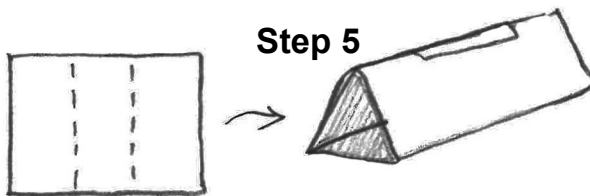

6. Tape the triangles (mirror stands) inside the box at the long ends.

7. Position a mirror at each end of the box so it is resting against the triangle. Explore which angle is best for the mirrors before taping them down.

8. Test out your periscope! What can you see?

Now that you have the basics figured out, how can you *improve* the periscope?

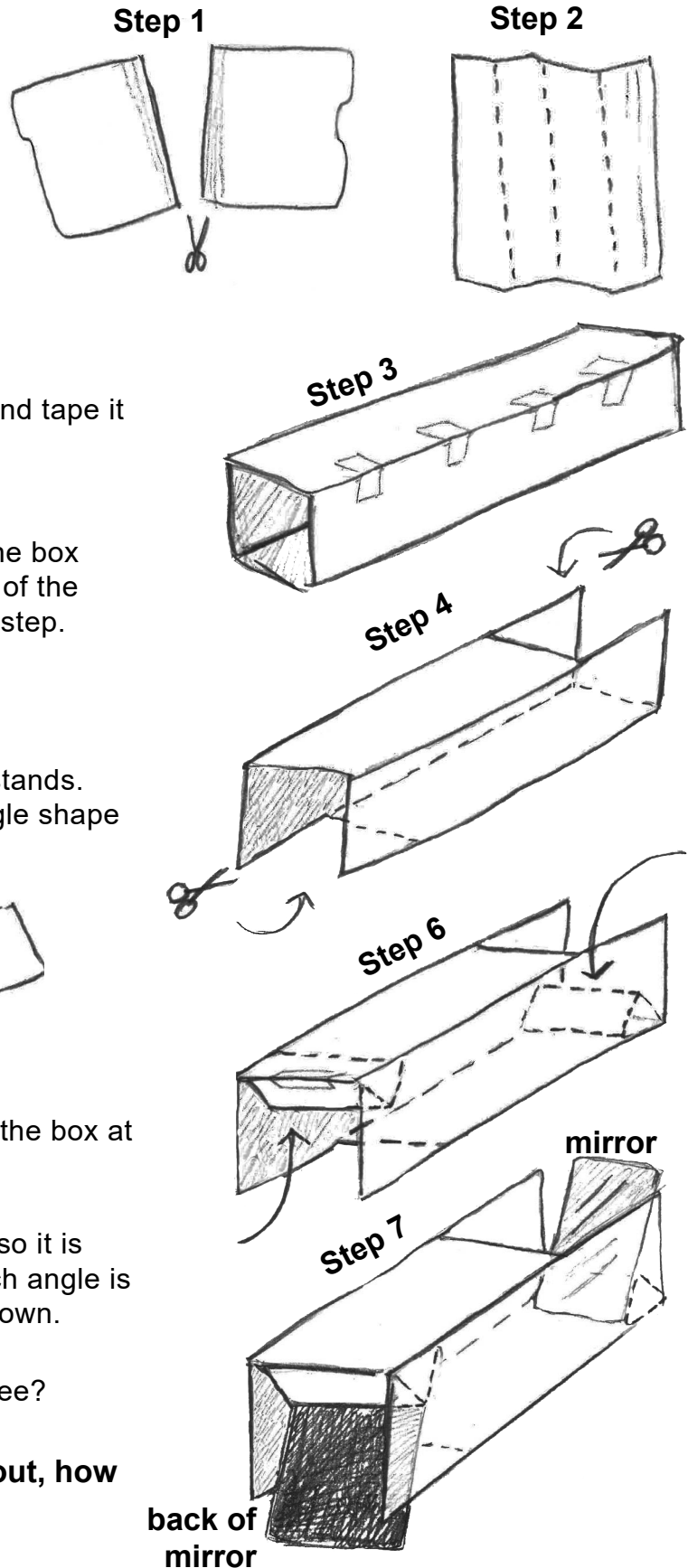

Can you engineer an *improved* periscope that can help you meet one or more of the following goals?

- Read words from across the room
- See over a very tall obstacle
- Look side to side without moving your head
- Meet a remote sensing goal that you decide!



Did You Know?

Periscopes are used in space travel. For example, the Russian Soyuz spacecraft has periscopes that help people dock the spacecraft at the Space Station.

Draw a *plan* for your improved periscope below.



Did You Know?

Radio waves, x-rays, gamma rays, and heat are different forms of light.